



# Ball Check Sight Glass Valve

**Lined ball check sight glass valve**



Size	15mm~200mm (0.5"~8")
Working pressure	0.1mbar~16 bar
Temperature range	-20° C ~ 200° C according to working conditions, other temperatures on request.
Design and Manufacture	API 594
Face to Face	ASME B16.10 DIN 3202 JIS B2002
Flange Ends	ASME B16.5 DIN 2532 JIS B2212
Visual Inspection	MSS Sp54
Testing	API 598 DIN 12569 JIS B2003
Pressure & Temperature	ASME B16.34
Spark testing	14kv

**Lined ball check sight glass valve**

With pressure rating up to 19 bargs, the SPECS ball check valves sight glass are very robust, having integrated borosilicate windows each side of the ball check assembly makes it very easy to see if there is flow through the valve. No wetted metal parts are used. The valves are immune to most aggressive chemicals and are used in place of expensive exotic alloys.

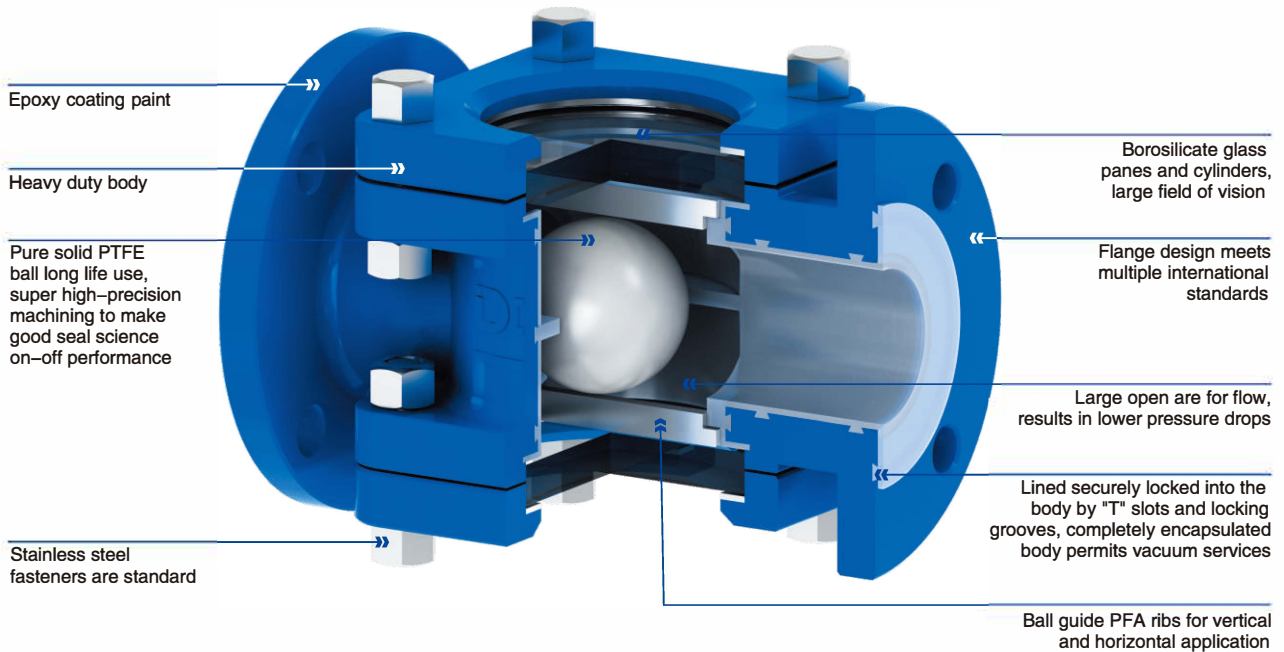

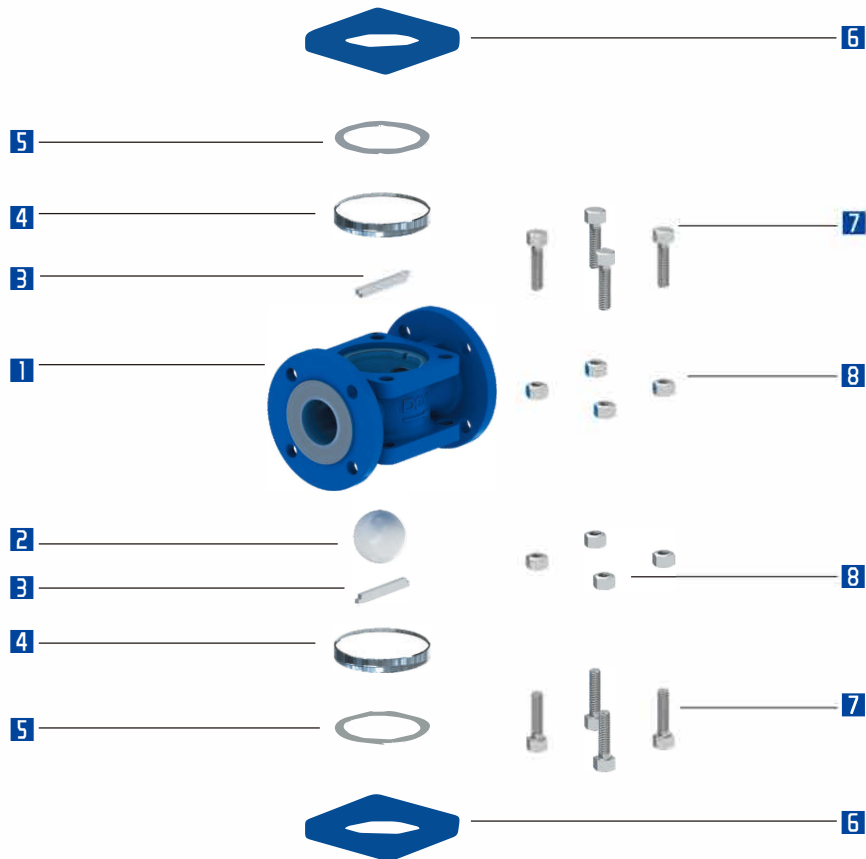

## MATERIALS SELECTION

No	Name	Qty	Materials	Materials According to Norms		
				ASTM	JIS	DIN
1	BODY	1	Carbon Steel+PFA/FEP/ETFE	A216-WCB	G5151 SCPH2	GS-45(1.0446)
			Stainless Steel+PFA/FEP/ETFE	A351-CF8	G5121 SCS13A	G-X6CrNiMo1810
			Ductile Iron+PFA/FEP/ETFE	ASTM A395	FCD400	GGG-40 ( 0.7040)
2	BALL	1	PTFE	-	-	-
3	BARRIER STRIP	2	PTFE/PFA/FEP/ETFE	-	-	-
4	TEMPERED SIGHT GLASS	2	Tempered Borosilicate Glass	-	-	-
5	ENVELOPE GASKET	2	PTFE	-	-	-
6	LENS FRAME	2	Carbon Steel+PFA/FEP/ETFE	A216-WCB	G5151 SCPH2	GS-45(1.0446)
			Stainless Steel+PFA/FEP/ETFE	A351-CF8	G5121 SCS13A	G-X6CrNiMo1810
			Ductile Iron+PFA/FEP/ETFE	ASTM A395	FCD400	GGG-40 ( 0.7040)
7	HEX BOLT	5	Stainless Steel	A 182 F304	G4303-SUSF304	X5CrNi18 10 DIN 17440
8	HEX NUT	5	Stainless Steel	A 182 F304	G4303-SUSF304	X5CrNi18 10 DIN 17440

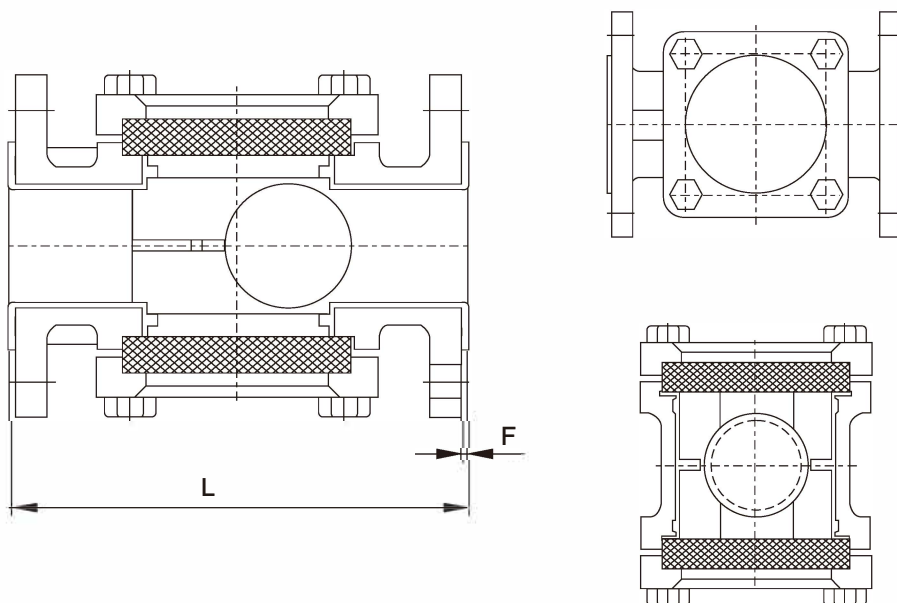

## DIMENSIONS \* Unit: mm

DN	NPS	ASME B16.5		JIS B2212 10K		DIN2532 Pn10		Weight [kg]	CV
		L	f	L	f	L	f		
15	½	160	3	160	3	160	3	4	11
20	¾	160	3	160	3	160	3	4.5	20
25	1	160	3	160	3	160	3	5.0	32
40	1½	200	3	200	3	200	3	8.5	90
50	2	230	4	230	4	230	4	12.5	140
80	3	310	4	310	4	310	4	22.5	375
100	4	350	4	350	4	350	4	31	610
150	6	480	4	480	4	480	4	59	1450
200	8	600	4	600	4	600	4	82	2050

[www.specsvalve.com](http://www.specsvalve.com)



**WENZHOU SPECS VALVE CO., LTD**

Tel:+86-577-67379084

Fax:+86-577-66997700

Email:[info@specsvalve.com](mailto:info@specsvalve.com)

Add:Dong'ou Industrial Zone, Oubei Town,  
Wenzhou City, Zhejiang Province, China

---