

SPECS VALVE

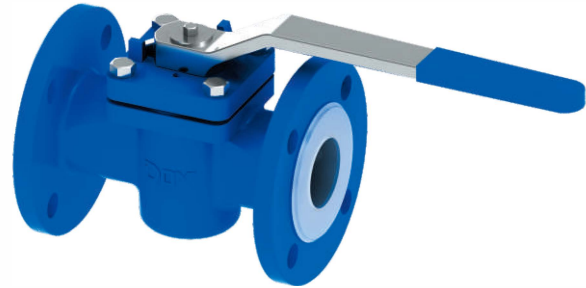

Plug Valve

Size	15mm~300mm (0.5"~12")
Working pressure	0.1mbar~16 bar
Temperature range	-20° C ~ 200° C according to working conditions, other temperatures on request.
Design and Manufacture	API 599
Face to Face	ASME B16.10 DIN 3202 JIS B2002
Flange Ends	ASME B16.5 DIN 2532 JIS B2212
Visual Inspection	MSS Sp54
Testing	API 598 DIN 12569 JIS B2003
Pressure & Temperature	ASME B16.34
Operator Type	Lever/ Gear/ Pneumatic/ Electric
Spark testing	14kv



■ Lined plug valve

SPECS straight through lined plug valves provide unrestricted flow when fully open, and are also operable in a throttled position.

The moulded liner assure excellent chemical resistance and long service life.

SPECS products are manufactured using latest production methodology backed by continuing quality control form raw materials to finish products to ensure the highest possible quality standards

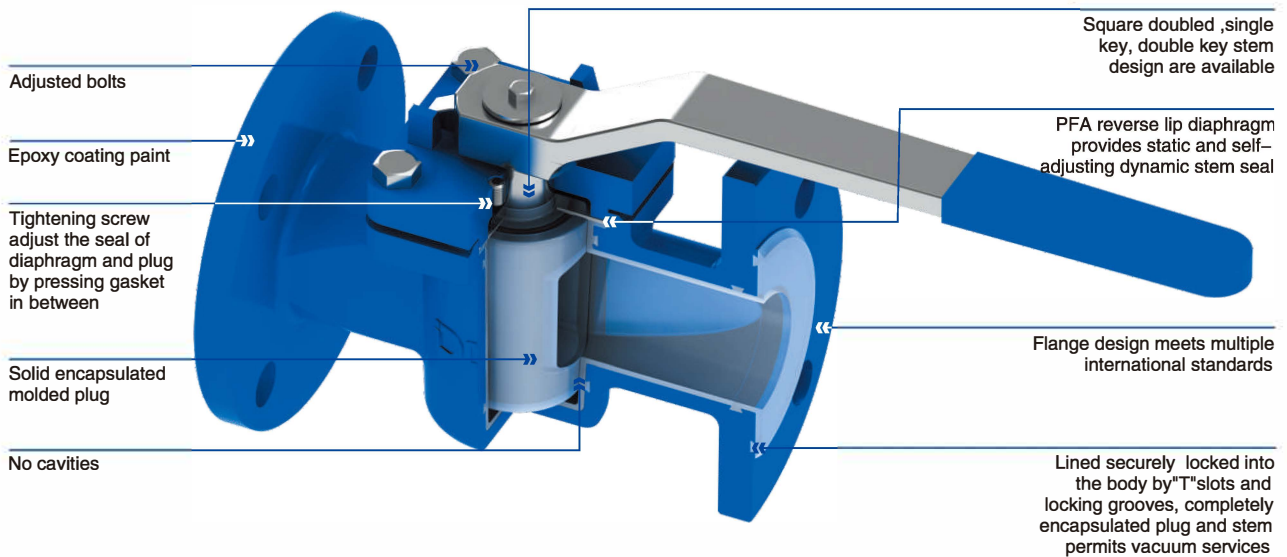

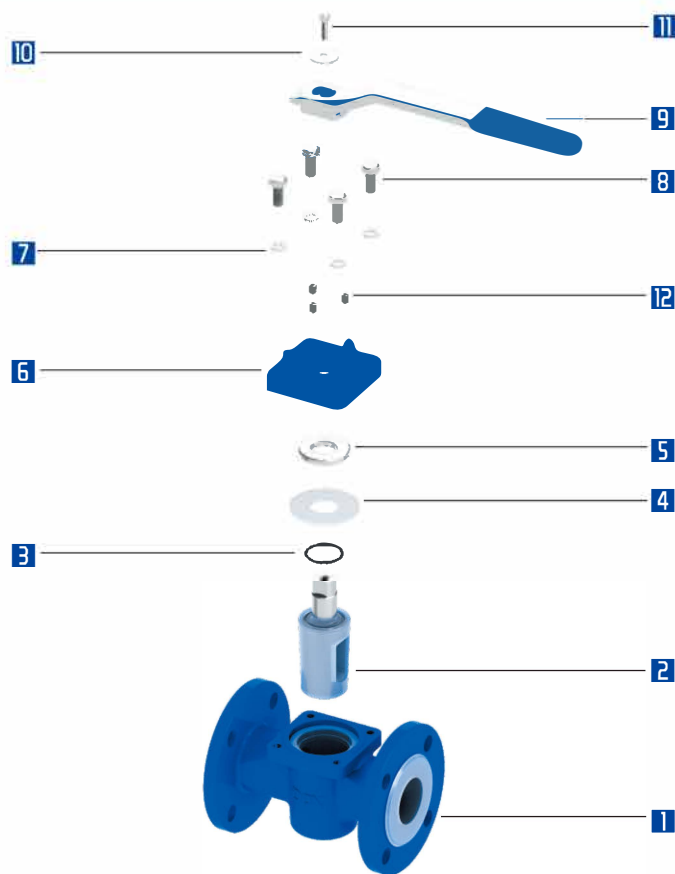

MATERIALS SELECTION

No	Designation	Qty.	Materials	Materials According to Norms		
				ASME	JIS	DIN
1	BODY	1	Carbon Steel+PFA/FEP/ETFE	A216-WCB	G5151 SCPH2	GS-45(1.0446)
			Stainless Steel+PFA/FEP/ETFE	A351-CF8	G5121 SCS13A	G-X6CrNiMo1810
			Ductile Iron+PFA/FEP/ETFE	ASTM A395	FCD400	GGG-40 (0.7040)
2	ONE-PIECE PLUG	1	Carbon Steel+PFA/FEP/ETFE	A216-WCB	G5151 SCPH2	GS-45(1.0446)
			Stainless Steel+PFA/FEP/ETFE	A351-CF8	G5121 SCS13A	G-X6CrNiMo1810
			Ductile Iron+PFA/FEP/ETFE	ASTM A395	FCD400	GGG-40 (0.7040)
3	O-RING	1	VITON	-	-	-
4	DIAPHRAGM	1	PFA/PTFE	-	-	-
5	GASKET	1	Stainless Steel	A 182 F304	G4303-SUSF304	X5CrNi18 10 DIN 1.4301
6	BONNET	1	Carbon Steel	A216-WCB	G5151 SCPH2	GS-45(1.0446)
			Stainless Steel	A351-CF8	G5121 SCS13A	G-X6CrNiMo1810
			Ductile Iron	ASTM A395	FCD400	GGG-40 (0.7040)
7	WASHER	4	Stainless Steel	A 182 F304	G4303-SUSF304	X5CrNi18 10 DIN 1.4301
8	BONNET BOLT	4	Stainless Steel	A 182 F304	G4303-SUSF304	X5CrNi18 10 DIN 1.4301
9	HANDLE	1	Stainless Steel	A 182 F304	G4303-SUSF304	X5CrNi18 10 DIN 1.4301
10	WASHER	1	Stainless Steel	A 182 F304	G4303-SUSF304	X5CrNi18 10 DIN 1.4301
11	HUB BOLT	1	Stainless Steel	A 182 F304	G4303-SUSF304	X5CrNi18 10 DIN 1.4301
12	SCREW	3	Stainless Steel	A 182 F304	G4303-SUSF304	X5CrNi18 10 DIN 1.4301

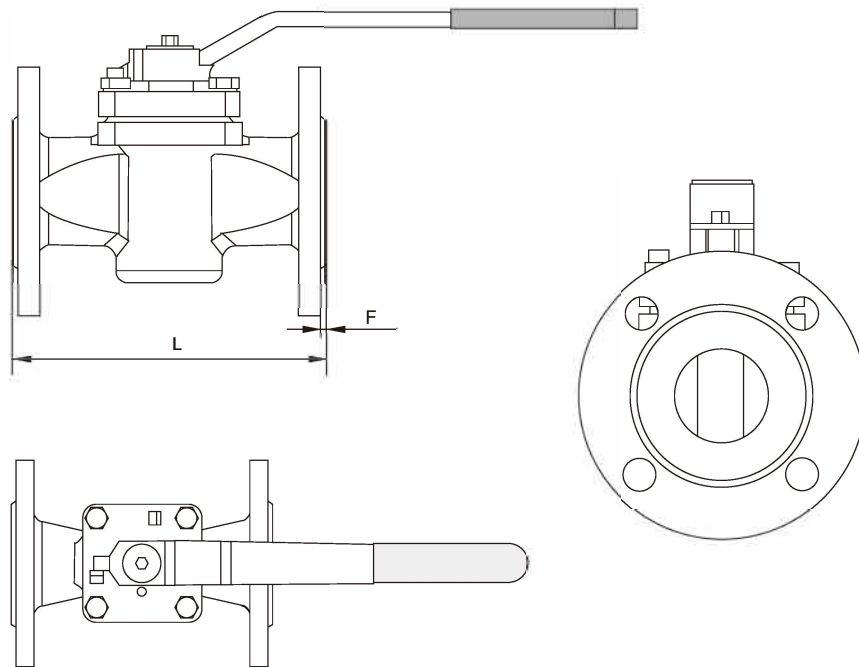
* Unit: mm **DIMENSION**

DN	NPS	ASME B16.5		JIS B2212 10K		DIN2532 Pn10		Weight	CV
mm	in	L	f	L	f	L	f	[kg]	
15	½	108	2	130	2	130	2	2.4	10
20	¾	117	2	150	2	150	2	2.4	12
25	1	127	2	160	2	160	2	3.4	17
40	1½	165	2	200	2	200	2	4.9	39
50	2	178	2	230	2	230	2	6	70
80	3	203	2	310	2	310	2	9	180
100	4	229	2	350	2	350	2	19	305
150	6	267	2	480	2	480	2	48	712
200	8	292	2	600	2	600	2	65	1011
250	10	330	2	730	2	730	2	88	1840
300	12	356	2	850	2	850	2	125	2435

www.specsvalve.com



WENZHOU SPECS VALVE CO., LTD

Tel: +86-577-67379084

Fax: +86-577-66997700

Email: info@specsvalve.com

Add: Dong'ou Industrial Zone, Oubei Town,
Wenzhou City, Zhejiang Province, China
