

Instruction and Operation Manual

Check Valves

Doc.No.: SPECS-IOM-CV

Date: 08/2020



CONTENTS

1. General
2. Essential health & safety requirements of PED
3. Application Scope and Technical Parameters
4. Valve Structure
5. Main Parts and Material
6. Working Principle and Structure Description Valve
7. Transportation
8. Valve Storage
9. Valve Installation
10. Valve Operation and Maintenance
11. Potential Failure and Troubleshooting
12. Quality Warrant
13. Servicing

1. General

Thanks for your selection of SPECS's check valve. As a type of pressure equipment, valve has potential hazards of pressure resulting from leakage of process fluid. For the safety purpose, user shall read this instruction to know what SPECS has already taken into account in our design and manufacture, and what action shall be taken by user according to essential health and safety requirements of European Directive 2014/68/EU .

2. Essential health & safety requirements of PED

2.1 Whats SPECS design idea

-Check valve are designed as standard product, no consideration of each specific service condition since its too wide.

-Check valve is designed to BS1868 ,API 6D, valve has adequate strength according to ASME B16.34 pressure-temperature rating. The check valve was EC-type approved by European Notified Body.

-Valve has different sealing materials in accordance with BS1868, API 6D which are corrosion/wear resistance to certain type of fluid.

2.2 What action user shall taken

2.2.1 General

2.2.1.1 In any occurrence, first ensure personnel safety.

2.2.1.2 Use the valves in accordance with ASME B16.34 pressure-temperature rating.

2.2.1.3 Make sure that the selected valve materials are corrosion/wear resistance to the service fluid.

2.2.1.4 Where the service fluid is flammable/explosive, to limit the working temperature.

2.2.1.5 When performing Repair/maintenance operations, make sure that the valves are always depressurized, vented and drained.

2.2.1.6 When performing Repair/maintenance operations, always use appropriate protection e.g. protective clothing, (oxygen) masks, gloves, etc.

2.2.1.7 When performing Repair/maintenance operations, do not smoke, do not use any portable no-Ex-proof electrical device in the area and do not use open fire without a valid work permit.

2.2.1.8 Valve must periodically checked on:

-Tightness of bolted connection (body/bonnet, flange connection).

-Corrosion/wear damages (crack, pitting, thickness of the valve).

2.2.2 Specifics

Risk	Preventive Action
<p>Accidental contact with dangerous service fluid* Due to: Gasket Blow out</p>	<ol style="list-style-type: none"> 1. See 2.2.1 General 2. Immediately replace Gasket after a Blow-out (use approved/suitable materials only) 3. Use recommended torque as in Table 5
<p>Accidental contact with dangerous service fluid* during disassembly or maintenance operations</p>	<ol style="list-style-type: none"> 1. See 2.2.1 General 2. After removal from the production line, open and close valve to guarantee depressurized cavity. 3. Drain any remainder fluid or substances with suitable devices before disassembly.
<p>Structural yielding of valves body with consequent risk of contact with dangerous service medium*,</p>	<ol style="list-style-type: none"> 1. See 2.2.1 General 2. Create precautions to avoid additional forces on the valves 3. Avoid absolutely water hammer: install precaution devices if necessary (e.g. brakes, anti shock devices, etc.) 4. Avoid submitting excessive vibrations to the valves. 5. Avoid quick Pressure and/or Temperature deviations.
<p>Accidental contact with High or Low temperature parts</p>	<ol style="list-style-type: none"> 1. See 2.2.1 General 2. Predispose apposite insulation on the valve. 3. Alert by means of warning signs about risk of burns. 4. For Cryogenic-/High Temperature service use only valves equipped with Cryogenic-/High Temp. Extension.
<p>Fire or explosion in case of service with flammable fluids</p>	<ol style="list-style-type: none"> 1. See 2.2.1 General 2. Install only Ex-proof electrical devices in the area 3. While performing maintenance in the area, shut down all electrical devices.

Explosion in case of oxygen service	1. See 2.2.1 General
	2. Install only Ex-proof electrical devices in the area.
	3. Install and use only valves completely degreased.
	4. Use valves only made with materials suitable for oxygen service (see EN 1797-1)

* Dangerous service fluid as there are: Toxic-, Corrosive-, Flammable-, High- or Low temperature etc. fluid

3. Application Scope and Technical Parameters

3.1 Application scope

The series valves are widely used in petroleum, chemical, power plant and allied industries for normal operation of pipeline system against converse movement of fluid

3.2 Technical Parameters:

Design standard: BS1868, API 6D ,ASME B16.34

Flange dimension: ASME B16.5

Structure length: ASME B16.10

Nominal pipeline size: 50~400 mm (2~16")

Nominal pressure: 20~100 bars (CLASS 150~600)

Temperature range: see Table3

Medium: see Table 3

Body material: ASTM material, see Table 1

Trim material: API 600 trim material, see Table 2

Valve testing: API598, API 6D

4. Valve Structure

Please refer to Figure 1 and 2 for valve structure.

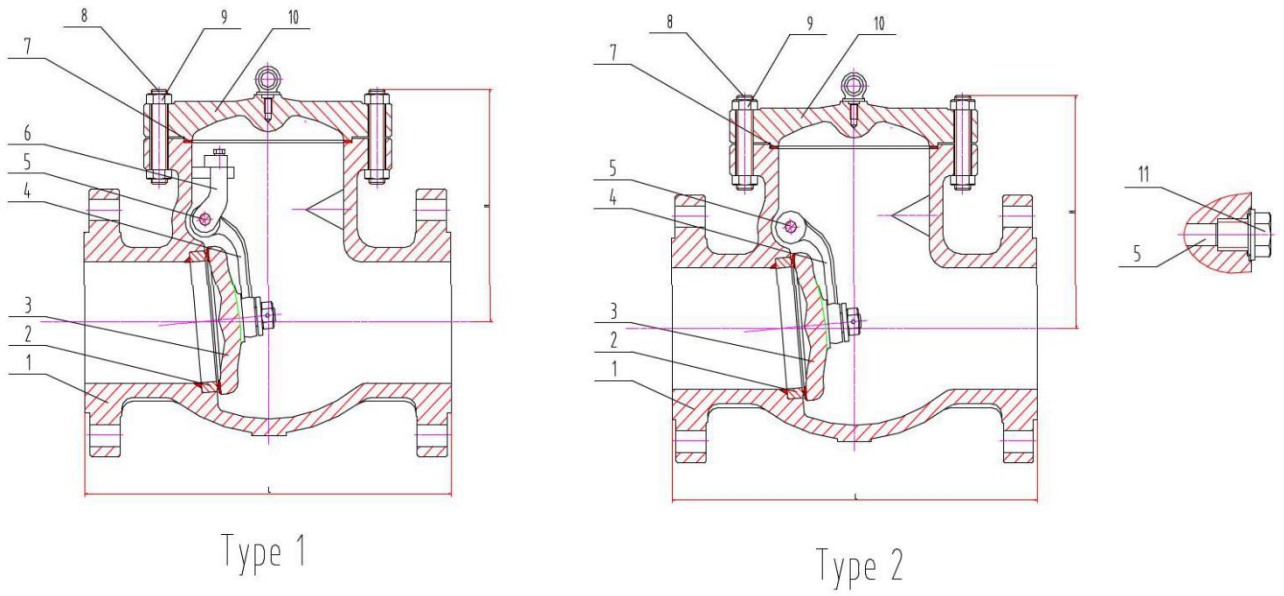

Fig 1 . SWING CHECK VALVE STRUCTURE

Check valve dimensions and weight refer to SPECS

5. Main Parts and Material

The user or the pipeline system designer must select valve body material and the class according to the working temperature, working pressure, the type of fluid and standard temperature-pressure rating as specified in ASME B16.34. The manufacturer takes only the responsibilities for use the order material and the valve class, no responsibility for incoherence of user selected material and valve class with the working condition.

Table 2 Common used trim material

API 600 Trim No.	Seat ring	Disc sealing	Hinge Pin
1	ER410	ER410	ASTM A182 F6a
2	304	304	ASTMA182F304
5	STL	STL	ASTM A182 F6a
8	STL	ER410	ASTM A182 F6a
9	Monel	Monel	Monel
10	316	316	ASTM A182 F316
12	STL	316	ASTM A182 F316

Table 3 body material suitable for fluid and temperature range

	ASTM A216-WCB	ASTM A352-LCB	ASTM A352-LCC	ASTM A217-WC6	ASTM A217-WC9	ASTM A351-CF8	ASTM A351-CF8M	ASTM A351-CF3	ASTM A351 - CF3M
RECOMMEND TEMPERATURE LIMITS (°C)	-29~427	-46~343		-29~593		-29~537		-29~427	-29~454
APPLICATION	STEAM, WATER, OIL VAPOUR, GAS and GENERAL SERVICE	LOW TEMPERATURE SERVICE STEAM, WATER, OIL VAPOUR, GAS		HIGH TEMPERATURE SERVICE STEAM, WATER, OIL VAPOUR, GAS		HIGH and LOW TEMPERATURE SERVICE CORROSION RESISTANCE			

Note: where the process fluid is flammable/explosive, it must limit the working temperature of the pipeline system.

6. Working Principle and Structure Description

6.1 Working principle

This series is a single direction check valve, when fluid flows in the normal direction, the disc opens to fluid pressure; when fluid flows in the reverse direction, the disc closes due to gravity and reverse fluid pressure and cuts off the bore.

6.2 Structure description

6.2.1 Flange end or butt welding end may be selected as per purchaser's optimum.

6.2.2 Valves use a reinforced flexible graphite gasket or spiral wound gasket. ..

6.2.3 The Disc seal is used for the valve and the seal material is applied to API 600 or to the customer requirements.

7. Valve Transportation

7.1 Valves are heavy and metal products, care shall be taken to avoid physical injury during transportation. Before transportation, cord and lift device and transportation tool shall be ready, valve package inspected and broken package repaired. Packaging shall conform to specification requirements.

Valve shall be handled with care, no damage the flange end or butt welding end.

7.2 The paint, nameplate and flange sealing surface shall be protected during transportation, no drag valve on the ground especially with the end sealing surface contacted the ground.

7.3 Don't unpack when the valve is not ready for installation at the construction field. The valve shall be placed at a safety location against whether.

8. Valve Storage

8.1 Valve shall be stored in air and dry room with bore blanked and flange sealing surface protected.

8.2 Long-time-stored valve shall be re-inspected prior to use. Close attention shall be paid against sealing damage when removal of dirties for the cleanness of sealing surface. Of necessary, valve shall be pressure tested once more.

9. Valve Installation

9.1 Carefully check valve identification against valve specifications before installation. The fluid flow direction in pipeline must be consistent with the arrow direction indicated on the body.

9.2 If there is pressure pulse/surge source, the check valve shall be installed far away from the source.

9.3 Check the inside of bore and the sealing surface before installation, any attached dirty shall be removed with clean soft cloth.

9.4 For valve with flange end, user shall select proper bolt, gasket according to the working temperature, working pressure and fluid, equally fasten the bolts and nuts. Bolt shall be with full thread and 8UN serial thread shall be used for bolt over 1 inch in diameter.

9.5 For valve with butt-welding end, user shall perform welding and post welding heat treatment using qualified WPS and welder in accordance with the requirements of ASMEB31.3.

10. Valve Operation and Maintenance

10.1 The online valve shall not be knocked, walked on or used as weight support.

10.2 Usually check valves have no heat insulation structure, never touch the surface of valves to prevent burn when the valve has a high/low surface temperature.

10.3 After put into service, valve shall be checked and maintained periodically especially for the condition of sealing surfaces and worn, and the corrosion of body. In case of such situation, valve

shall be repaired or replaced. It is suggested that inspection and maintenance of valve shall be performed every three months provided the fluid is water or oil, every month or to local law provided the fluid is strong corrosive.

10.4 When performing Repair/maintenance operations, user shall use valve gasket, bolt and nut

of the same size and material as the original one. Valve gasket may be ordered as spare parts for maintenance and replacement. It is forbidden to open the bonnet or replace the bolt or nut when the valve contains pressure. After replacement of gasket, bolt and nut, valve shall be pressure tested prior to reuse.

10.5 User may repair the valve-sealing surface providing a successful closure test is performed and the sealing is ok.

10.6 Generally valve trim prefers replacement to reparation. It is better to use provided part as

replacement. If part produced by valve manufacturer is not available due to emergency, user shall produce the part to SPECS's technical documentation. SPECS takes no responsibility for loss caused out of part produced from outsourcing.

10.7 It is not recommended for reparation of valve pressure-containing part by user. If the

pressure-containing part is used for a long time and consequently deflection occurs and affect safety use, user shall replace the valve with a new one.

10.8 Welding repair on valve online is forbidden.

11. Potential Failure and Troubleshooting

Failure	Cause	Troubleshooting
Leakage between sealing surfaces	1. Dirties between sealing surfaces 2. Sealing surfaces damaged	1. Clean sealing surface 2. Repair the sealing surfaces
Operation failure	1. Arm device in a wrong position. 2. The wear of arm, disc and pin connection.	Cut off the fluid and dismount the valve, repair the valve or replace part
	3. Arm deformation or rupture	
Leakage between bonnet flanges	1. Bonnet bolts loose 2. Bonnet gasket failure	1. Proper tighten bonnet nuts 2. Replace bonnet gasket

<p>Body and bonnet broken and leaked</p>	<p>1. Water hammer 2. Fatigue 3. Freezing broken</p>	<p>1. Replace valve that exceeds guarantee period or is found with early fatigue defection 2. Drain away water in winter when valve is not used</p>
--	--	---

12. Quality Warrant

- 12.1 SPECS warranty its valves to the original purchaser for a period of 18 months from and after the date of delivery to the original customer, against defects in material and workmanship under proper and normal use and service and not caused of resulting from improper application or usage, improper installations, improper maintenance and repairs, modifications or alterations.
- 12.2 Purchaser shall give notice to SPECS upon finding of any defect or assuming defect, SPECS has privilege to check the facts of the defect.
- 12.3 SPECS sole obligation under this warranty shall be limited to the follows:
 - repair of the material or,
 - replacement of the parts and materials or,
 - refund the purchase price or collect the defected products from the original purchaser.
- 12.4 SPECS is not responsible to claims caused from unexpected natural disaster such as earthquake, typhoon of any kind arising out of the defect.
- 12.5 The scope and limitation of warranty can be changed through the agreement between SPECS and purchaser.

13. Servicing

- 13.1 Where contractually specified, SPECS may provide field installation and adjustment.
- 13.2 SPECS will trace the quality of sold valve and provide service to customer requirements..