

## Instruction and Operation Manual

### Globe Valves

Doc.No.: SPECS-IOM-GV

Date: 08/2020



#### CONTENTS

1. General
2. Essential health & safety requirements of PED/Atex and solution
3. Application scope and Technical Parameters
4. Valve Structure
5. Main Parts and Material
6. Working Principle and Structure Description
7. Valve Transportation
8. Valve Storage
9. Valve Installation
10. Valve Operation and Maintenance
11. Potential Failure and Troubleshooting
12. Quality Warrant
13. Servicing

### 1. General

Thanks for your selection of SPECS's globe valve. As a type of pressure equipment, valve has potential hazards of pressure and creation of explosive atmosphere resulting from leakage of process fluid. For the safety purpose, user shall read this instruction to know what SPECS has already taken into account in our design and manufacture, and what action shall be taken by user according to essential health and safety requirements of European Directive 97/23/EC(PED) and 94/9/EC (Atex).

### 2. Essential health & safety requirements of PED/Atex and solution

#### 2.1 Whats SPECS design idea

-Globe valve is designed as standard product, no consideration of each specific service condition since its too wide.

-Globe valve is designed to BS1873, valve has adequate strength according to ASME B16.34 pressure-temperature rating. The globe valve was EC-type approved by European Notified Body.

-Valve has different sealing materials in accordance with BS1873, which are corrosion/wear resistance to certain type of fluid.

-Valve contains no light metal (such as Mg) and all parts are electricity conductive and connected together to prevent ignite resource.

-Valve is designed with hand wheel, or gear operator or electric actuator according to its size and torque, and operation requirements.

#### 2.2 What action user shall taken

##### 2.2.1 General

2.2.1.1 In any occurrence, first ensure personnel safety.

2.2.1.2 Use the valves in accordance with ASME B16.34 pressure-temperature rating.

2.2.1.3 Make sure that the selected valve materials are corrosion/wear resistance to the service fluid.

2.2.1.4 Where the service fluid is flammable/explosive, to limit the working temperature.

2.2.1.5 When performing Repair/maintenance operations, make sure that the valves are always depressurized, vented and drained.

2.2.1.6 For actuator operated valves, make sure all supply lines (Electrical, hydraulic, Air) are disconnected before starting any operation.

2.2.1.7 When performing Repair/maintenance operations, always use appropriate protection e.g. protective clothing, (oxygen) masks, gloves, etc.

2.2.1.8 When performing Repair/maintenance operations, do not smoke, do not use any

portable no-Ex-proof electrical device in the area and do not use open fire without a valid work permit.

2.2.1.9 Valve must periodically checked on:

- Tightness of bolted connection (body/bonnet, gland, flange connection).
- Corrosion/wear damages (crack, pitting, thickness of the valve).
- Make sure the valves are in fully open/fully closed position.

2.2.2 Specifics

<b>Risk</b>	<b>Preventive Action</b>
Accidental contact with dangerous service fluid*  Due to: Gasket or Packing Blow out	1. See 2.2.1 General
	2. Immediately replace Gasket and packing after a Blow-out (use approved/suitable materials only)
	3. Use recommended torque as in Table 5 and Table 6
Accidental contact with dangerous service fluid* during disassembly or maintenance operations	1. See 2.2.1 General
	2. After removal from the production line, open and close valve to guarantee depressurized cavity.
	3. Drain any remainder fluid or substances with suitable devices before disassembly.
Structural yielding of valves body with consequent risk of contact with dangerous service medium*, explosion or fire	1. See 2.2.1 General
	2. Create precautions to avoid additional forces on the valves
	3. Avoid absolutely water hammer: install precaution devices if necessary (e.g. brakes, anti shock devices, etc.)
	4. Avoid submitting excessive vibrations to the valves.
	5. Avoid quick Pressure and/or Temperature deviations.
Accidental contact with High or Low temperature parts	1. See 2.2.1 General
	2. Predispose apposite insulation on the valve.
	3. Alert by means of warning signs about risk of burns.
	4. For Cryogenic-/High Temperature service use only valves equipped with Cryogenic-/High Temp. Extension.
Fire or explosion in case of service with flammable fluids	1. See 2.2.1 General
	2. Install only Ex-proof electrical devices in the area
	3. While performing maintenance in the area, shut down all electrical devices.
Explosion in case of oxygen service	1. See 2.2.1 General
	2. Install only Ex-proof electrical devices in the area

	3. Install and use only valves completely degreased.
	4. Use valves only made with materials suitable for oxygen service (see EN 1797-1)

Dangerous service fluid as there are: Toxic-, Corrosive-, Flammable-, High- or Low temperature etc. fluid

**3. Application Scope and Technical Parameters**

3.1 Scope

The series valves are widely used in petroleum, chemical, power plant and allied industries for normal operation of pipeline system by cut off or connect the pipeline.

3.2 Technical Parameters:

- Design standard: BS1873, ASME B16.34
- Flange dimension: ASME B16.5
- Structure length: ASME B16.10
- Nominal pipeline size: 50~300 mm (2~18")
- Nominal pressure: 20~250 bars (150~1500LB)
- Temperature range: see Table 3
- Medium: see Table 3
- Body material: ASTM material, see Table 1
- Trim material: API 600 trim material, see Table 2
- Valve testing: API598
- Applicable ATEX: II 2 GD c

**4. Valve Structure**

Please refer to Figure 1 and 2 for valve structure.

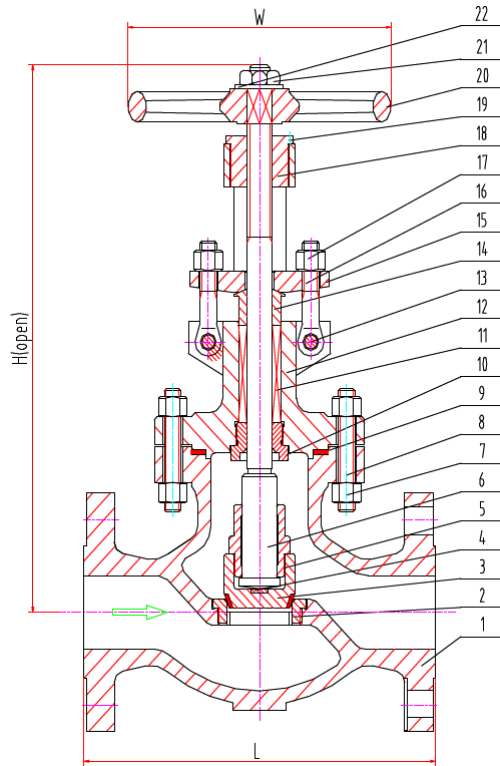

Fig.1 150LB/300LB

GLOBE VALVE STRUTURE

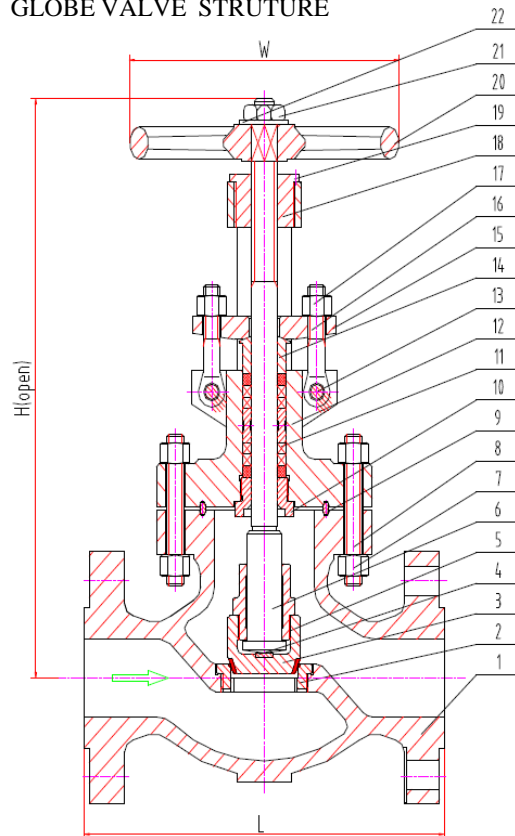

Fig.2 600LB/900LB/1500LB/2500LB

GLOBE VALVE STRUTURE

- Globe valve dimensions and weight refer to SPECS.

**5. Main Parts and Material**

The user or the pipeline system designer must select valve body material and the class according to the working temperature, working pressure, the type of fluid and standard temperature-pressure rating as specified in ASME B16.34. The manufacturer takes only incoherence of user selected material and valve class with the working condition.

Table 1 Valve main parts and material

ITEM	PART NAME		CARBON STEEL			ALLOY STEEL		STAINLESS STEEL				
1	Body		A216 WCB	A352 LCB	A352 LCC	A217 WC6	A217 C5	A351 CF8	A351 CF8M	A351 CF3	A351 CF3M	A351 CF8C
2	Seat Ring		A105	A350 LF2	A350 LF2	A182 F11	A182 F5	A182 F304	A182 F316	A182 F304L	A182 F316L	A182 F321
3	Disc		A216WCB	A352 LCB	A352 LCC	A217 WC6	A217 C5	A351 CF8	A351 CF8M	A351 CF3	A351 CF3M	A351 CF8C
4	Disc Thrust Plate		A276 420	A276 304	A276 304	A276 420		A276 304	A276 316	A276 304L	A276 316L	A276 321
5	Disc Nut		A276 410	A276 304	A276 304	A276 410		A276 304	A276 316	A276 304L	A276 316L	A276 321
6	Stem		A182 F6	A182 F304	A182 F304	A182 F6	A182 F5	A182 F304	A182 F316	A182 F304L	A182 F316L	A182 F321
7	Bonnet Bolt Nuts		A194 2H	A194 4	A194 4	A194 4	A194 4	A194 8				
8	Bonnet Bolts		A193 B7	A320 L7	A320 L7	A193 B16	A193 B16	A193 B8				
9	Gasket	CL150-300	304+Graphite	304+Graphite		304+Graphite		304+Graphite	316+Graphite			
		CL600-2500 Ring Joint	304	304		304		304	316			
10	Backseat Bushing		A276 410	A276 304	A276 304	A276 410		A276 304	A276 316	A276 304L	A276 316L	A276 321
11	Stem Packing		Braided Graphite & Die formed Graphite Ring			Braided Graphite & Die formed Graphite Ring		Braided Graphite & Die formed Graphite Ring				
12	Bonnet		A216 WCB	A352 LCB	A352 LCC	A217WC6	A217 C5	A351CF8	A351 CF8M	A351 CF3	A351 CF3M	A351 CF8C
13	Eye Bolt Pins		Carbon Steel			A276 410		Stainless Steel				
14	Gland		A276 410	A276 304	A276 304	A276 410		A276 304	A276 316	A276 304L	A276 316L	A276 321
15	Gland Flange		A216 WCB	A352 LCB	A352 LCC	A217 WC6	A217 C5	A351CF8	A351 CF8M	A351 CF3	A351 CF3M	A351 CF8C
16	Gland Eye Bolts		A307 B	A320 L7	A320 L7	A193 B16	A193 B16	A193 B8				
17	Eye Bolt Nuts		A194 2H	A194 4	A194 4	A194 4	A194 4	A194 8	A194 8	A194 8	A194 8	A194 8
18	Yoke Bush		A439 D-2			A439 D-2		A439 D-2				
19	Screw		Carbon Steel			Carbon Steel		Stainless Steel				
20	Handwheel		Ductile Iron			Ductile Iron		Ductile Iron				
21	Handwheel Nut		Carbon Steel			Carbon Steel		Stainless Steel				
22	Washer		Carbon Steel			Carbon Steel		Stainless Steel				

Table 2 Common used trim material

API600 Trim No.	Seat ring	Disc sealing	Stem	Back seat
1	ER410	ER410	ASTM A182 F6a	ASTM A182 F6a
2	304	304	ASTMA182 F304	ASTMA182F304
5	STL	STL	ASTM A182 F6a	ASTM A182 F6a
8	STL	ER410	ASTM A182 F6a	ASTM A182 F6a
9	Monel	Monel	Monel	Monel
10	316	316	ASTM A182 F316	ASTMA182F316
12	STL	316	ASTM A182 F316	ASTMA182F316

Table 3 body material suitable for fluid and temperature range

	ASTM A216-WCB	ASTM A352-LCB	ASTM A352-LCC	ASTM A217-WC6	ASTM A217-WC9	ASTM A351-CF8	ASTM A351-CF8M	ASTM A351-CF3	ASTM A351-CF3M
RECOMMEND TEMPERATURE LIMITS (°C)	-29~427	-46~ 343	-46~ 343	-29~ 593	-29~ 593	-29~ 537	-29~ 537	-29~ 427	-29~ 454
APPLICATION	STEAM, WATER, OIL VAPOUR, GAS and GENERAL	LOW TEMPERATURE SERVICE STEAM, WATER, OIL VAPOUR, GAS		HIGH TEMPERATURE SERVICE STEAM, WATER, OIL VAPOUR, GAS		HIGH and LOW TEMPERATURE SERVICE CORROSION RESISTANCE			

Note: where the process fluid is flammable/explosive, it must limit the working temperature of the pipeline system.

## 6. Working Principle and Structure Description

### 6.1 Working principle

The series is globe valves. When hand-wheel rotate clockwise, the disc descends and the valve shuts off; when rotate counter clockwise, the disc ascends and the valve opens.

### 6.2 Structure description

6.2.1 Flange end or but welding end may be selected as to purchaser optimum.

6.2.2 Packing seal structure and flexible graphite combination packing is used for the series valve.

6.2.3 Class 150LB to 300LB valves use a reinforced flexible graphite gasket and 600to 2500LB



valves use ring joint metal gasket.

6.2.4 Cone sealing is used for the valve and the seal material is selected to API 600 or to the customer requirements.

6.2.5 For big valve, hand-wheel is replaced by gear operator , please see SPECS 's catalogue..

### 7. Valve Transportation

Valves are heavy and metal products, care shall be taken to avoid physical injury during transportation. Cord and lift device and transportation tool shall be ready, valve package inspected and broken package repaired. Packaging shall conform to specification

requirements, it is forbidden to rotate the hand-wheel when valve is packaged. Valve shall be in full-close status. For mis-opened valve, the sealing surface shall be cleaned and valve re-closed and ends of bore blocked. Actuator and valve shall be packaged separately.

During transportation or lifting, cord shall be tied to the yoke, no tied to the hand-wheel or stem. Valve shall be handled with care, no bump to other thing.

The paint, nameplate and flange sealing surface shall be protected during transportation,no drag valve on the ground especially with the end sealing surface contacted the ground.Don't unpack when the valve is not ready for installation at the construction field. The valve shall be placed at a safety location against weather.

### 8. Valve Storage

8.1 Valve shall be stored in air and dry room with bore blanked for protection.

8.2 Long-time-stored valve shall be re-inspected prior to use. Close attention shall be paid

against sealing damage when removal of dirties for the cleanness of sealing surface. Of necessary, valve shall be pressure tested once more.

### 9. Valve Installation

9.1 Carefully check valve identification against valve specifications before installation. Always keep the fluid flow direction with the arrow identified on the body.

9.2 Check the inside of bore and the sealing surface before installation, any attached dirty shall be removed with clean soft cloth.

9.3 Check the operational of actuator to prevent block before installation.

9.4 Valve operation device is recommended to be installed at location 1.2m from the ground

for convenient of operation. Where the center of valve and the hand-wheel is over 1.8m from the ground, a platform shall be built for the frequently operated valve. For pipeline with

- 9.5 numbers of valves, valves shall be installed on the same platform as likely as possible for convenient of operation.
- For single valve installed at location over 1.8m and less operated, apparatus may be used such as chain-wheel, extension bar, move platform and move ladder etc. Where valve is installed underground, extension bar or ground-well shall be set. For safety reason, the ground-well shall be covered.
- 9.6 For valve installed on horizontal pipeline, the stem is suitable at upright position; or, the downward stem shall be inconvenience for operation and maintenance, as well the valve is liable to corrosion. If the ground valve slant installed, operation and maintenance shall also be inconvenience.
- 9.7 When valves are installed in pipeline side by side, enough space shall be considerate for operation, maintenance and dismantle. The clearance of hand-wheels shall not less than 100mm; in case of narrow clearance, valves shall be installed interleaving.
- 9.8 For valve with flange end, user shall select proper bolt, gasket according to the working temperature, working pressure and fluid, equally fasten the bolts and nuts. Bolt shall be with full thread and 8UN serial thread shall be used for bolt over 1 inch in diameter.
- 9.9 For valve with butt-welding end, user shall perform welding and post welding heat treatment using qualified WPS and welder in accordance with the requirements of ASME B31.3.

## 10. Valve Operation and Maintenance

- 10.1 After installation and for the pressure test of the pipeline or the system, the disc must be fully opened. It is not recommended to use the valve as adjustment of flow rate or emergent pressure relief blow-off. SPECS is not responsible for damage, loss or expense arising out of such usage.
- 10.2 Usually globe valves have no heat insulation structure, never touch the surface of valves to prevent burn when the valve has a high/low surface temperature.
- 10.3 Dust, grease and medium residual trend to accumulate at the surfaces of body, and moving parts such as stem, gearbox, the guide of yoke etc., wear and erode the valve, and even generate friction heat that is dangerous in explosive atmosphere, and shall be cleaned frequently according to the working conditions.
- 10.4 After put into service, valve shall be checked and maintained periodically especially for the situation of sealing surfaces and worn, the age of packing and the corrosion of body. In

case of such situation, valve shall be repaired or replaced. It is suggested that inspection and maintenance of valve shall be performed every three months provided the fluid is water or oil, every month or to local law provided the fluid is strongly corrosive.

- 10.5 When performing Repair/maintenance operations, user shall use valve packing, gasket, bolt and nut of the same size and material as the original one. Valve packing and gasket may be ordered as spare parts for maintenance and replacement. It is forbidden to open the bonnet or replace the bolt, nut or packing when the valve contains pressure. After replacement of packing, gasket, bolt and nut, valve shall be closed and tested prior to reuse.
- 10.7 User may repair the valve-sealing surface providing a successful closure test is performed and the sealing is ok.
- 10.8 Generally valve trim prefers replacement to reparation. It is better to use provided part as replacement. If part produced by valve manufacturer is not available due to emergency, user shall produce the part to SPECS's technical documentation. SPECS takes no responsibility for loss caused out of part produced other than SPECS.
- 10.9 It is not recommended for reparation of valve pressure-containing part by user. If the pressure-containing part is used for a long time and consequently deflection occurs and affects safety use, user shall replace the valve with a new one.
- 10.10 Welding repair on valve online is forbidden.
- 10.11 The online valve shall not be knocked, walked on or used as weight support.

## **11. Potential Failure and Troubleshooting**

Failure (risk)	Cause	Troubleshooting
Leakage of packing	<ol style="list-style-type: none"> <li>1. Gland flange nuts loose</li> <li>2. Rings of packing not enough</li> <li>3. Packing aged or failure</li> <li>4. Stem sealing damaged</li> </ol>	<ol style="list-style-type: none"> <li>1. Equally tighten eyebolt nuts</li> <li>2. Add packing</li> <li>3. Replace packing</li> <li>4. Stem shall be maintained periodically by reparation or replacement conjunction with the maintenance of pipeline</li> </ol>
Leakage between sealing surfaces	<ol style="list-style-type: none"> <li>1. Dirties between sealing surfaces</li> <li>2. Sealing surfaces damaged</li> </ol>	<ol style="list-style-type: none"> <li>1. Clean sealing surface</li> <li>2. Repair the sealing surfaces</li> </ol>
Operation failure	<ol style="list-style-type: none"> <li>1. Packing too tight</li> <li>2. Thread of stem nut over worn</li> <li>3. Stem bent</li> <li>4. Foreigner existence between stem and stem nut or gland</li> </ol>	<ol style="list-style-type: none"> <li>1. Proper loose gland flange nuts</li> <li>2. Replace stem nut</li> <li>3. Rectify or replace stem</li> <li>4. Clean foreign matter</li> </ol>
Leakage between bonnet flanges	<ol style="list-style-type: none"> <li>1. Bonnet bolts loose</li> <li>2. Bonnet gasket failure</li> </ol>	<ol style="list-style-type: none"> <li>1. Proper tighten bonnet nuts</li> <li>2. Replace bonnet gasket</li> </ol>
Body and bonnet broken and leaked	<ol style="list-style-type: none"> <li>1. Water hammer</li> <li>2. Fatigue</li> <li>3. Freezing broken</li> </ol>	<ol style="list-style-type: none"> <li>1. Carefully operation to prevent suddenly stopping pumping and rapidly shutting.</li> <li>2. Replace valve that exceeds guarantee period or is found with early fatigue defection</li> <li>3. Drain away water in winter</li> </ol>

## 12. Quality Warrant

12.1 SPECS warrants its valves

the date of delivery to the original customer, against defects in material and workmanship under proper and normal use and service and not caused of resulting from improper

application or usage, improper installations, improper maintenance and repairs, modifications or alterations.

12.2 Purchaser shall give notice to SPECS upon finding of any defect or assuming defect, SPECS has privilege to check the facts of the defect

12.3 SPECS sole obligation under this warranty shall be limited to the follows:

—repair of the material or,

—replacement of the parts and materials or,

—refund the purchase price or collect the defected products from the original purchaser.

12.4 SPECS is not responsible to claims caused from unexpected natural disaster such as earthquake, typhoon of any kind arising out of the defect.

12.5 The scope and limitation of warranty can be changed through the agreement between SPECS and purchaser.

### **13. Servicing**

13.1 Where contractually specified, SPECS may provide field installation and adjustment.

13.2 SPECS will trace the quality of sold valve and provide service to customer requirements..