

SPECS VALVE



Diaphragm Valve

 **SPECS** VALVE



Lined diaphragm valve

Size	15mm~300mm (0.5"~12")
Working pressure	0.1mbar~16 bar
Temperature range	-20° C ~ 200° C according to working conditions, other temperatures on request.
Design and Manufacture	MSS SP-88
Face to Face	ASME B16.10 DIN 3202 JIS B2002
Flange Ends	ASME B16.5 DIN 2532 JIS B2212
Visual Inspection	MSS Sp54
Testing	API 598 DIN 12569 JIS B2003
Pressure & Temperature	ASME B16.34
Operator Type	Hand wheel/Pneumatic
Spark testing	14kv



■ Lined diaphragm valve

SPECS weir type diaphragm valve having rugged design to incorporating the best material available is proved by easy, smooth and maintenance free operation for a long time. Extra heavy-duty casting affords high resistance to atmospheric corrosion. SPECS diaphragm valve reduces diaphragm travel for extended service and fine control.

A wide choice is available for body materials, body linings, types of operation and body end connections to satisfy the needs of most industrial applications. High quality standards are strictly maintained, each valve being checked for size, design pressure, operation, MOC, finish etc and within house painting.

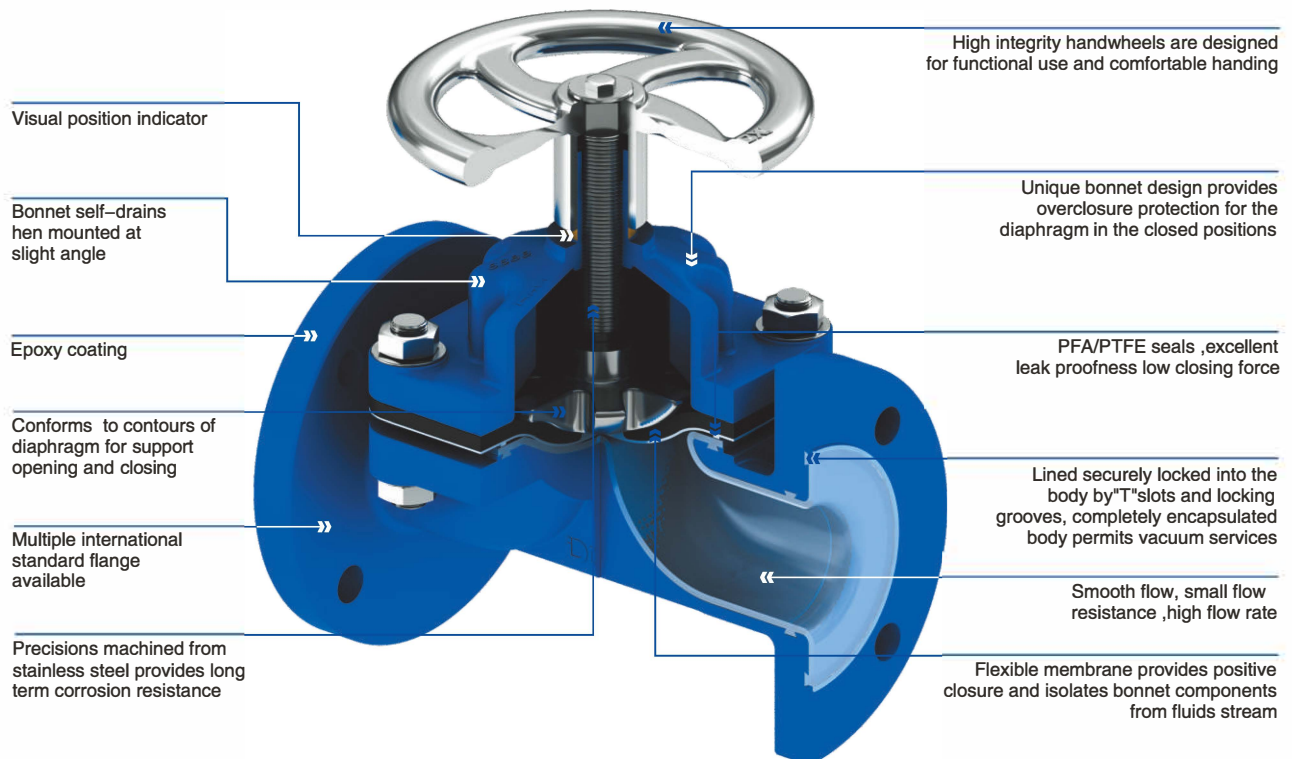

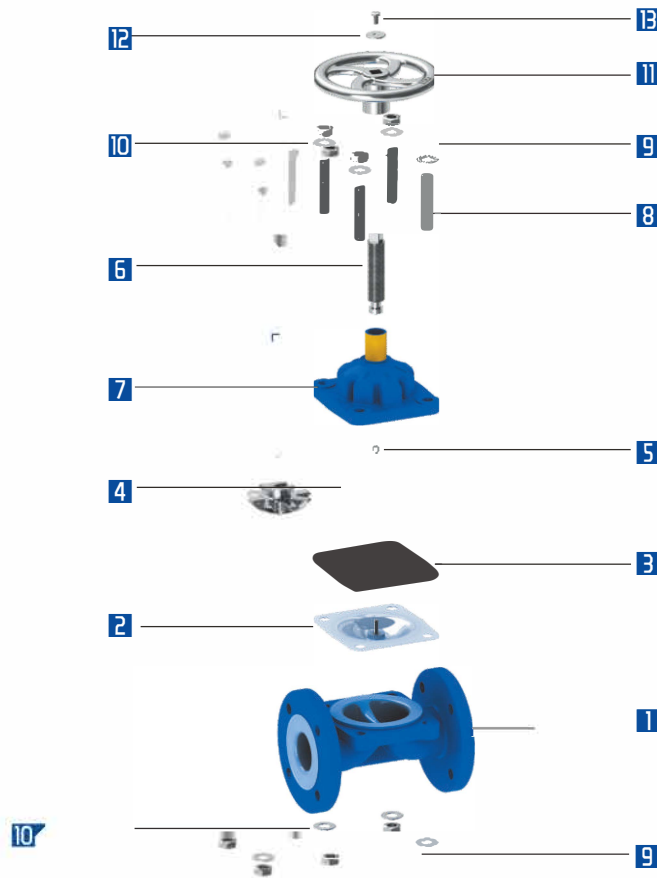

MATERIALS SELECTION

No	Name	Qty.	Materials	Materials According to Norms		
				ASTM	JIS	DIN
1	BODY	1	Carbon Steel+PFA/FEP/ETFE	A216-WCB	G5151 SCPH2	GS-45(1.0446)
			Stainless Steel+PFA/FEP/ETFE	A351-CF8	G5121 SCS13A	G-X6CrNiMo1810
			Ductile Iron+PFA/FEP/ETFE	ASTM A395	FCD400	GGG-40 (0.7040)
2	DIAPHRAGM	1	PFA/PTFE	-	-	-
3	CUSHION RUBBER		NBR	-	-	-
4	COMPRESSOR		Carbon Steel	A216 WCB	G5151-SCPH2	GS-C25N DIN 17245
5	LINK BLOCK	1	Stainless Steel	A 182 F304	G4303-SUSF304	X5CrNi18 10 DIN 17440
6	SPINDLE	1	Stainless Steel	A 182 F304	G4303-SUSF304	X5CrNi18 10 DIN 17440
7	BONNET	1	Carbon Steel	A216-WCB	G5151 SCPH2	GS-45(1.0446)
			Stainless Steel	A351-CF8	G5121 SCS13A	G-X6CrNiMo1810
			Ductile Iron	ASTM A395	FCD400	GGG-40 (0.7040)
8	STUD BOLT	4	Stainless Steel	A 182 F304	G4303-SUSF304	X5CrNi18 10 DIN 1.4301
9	HEX NUT	8	Stainless Steel	A 182 F304	G4303-SUSF304	X5CrNi18 10 DIN 1.4301
10	WASHER	8	Stainless Steel	A 182 F304	G4303-SUSF304	X5CrNi18 10 DIN 1.4301
11	HAND WHEEL	1	Stainless Steel	A 182 F304	G4303-SUSF304	X5CrNi18 10 DIN 1.4301
12	WASHER	1	Stainless Steel	A 182 F304	G4303-SUSF304	X5CrNi18 10 DIN 1.4301
13	WRENCH BOLT	1	Stainless Steel	A 182 F304	G4303-SUSF304	X5CrNi18 10 DIN 1.4301

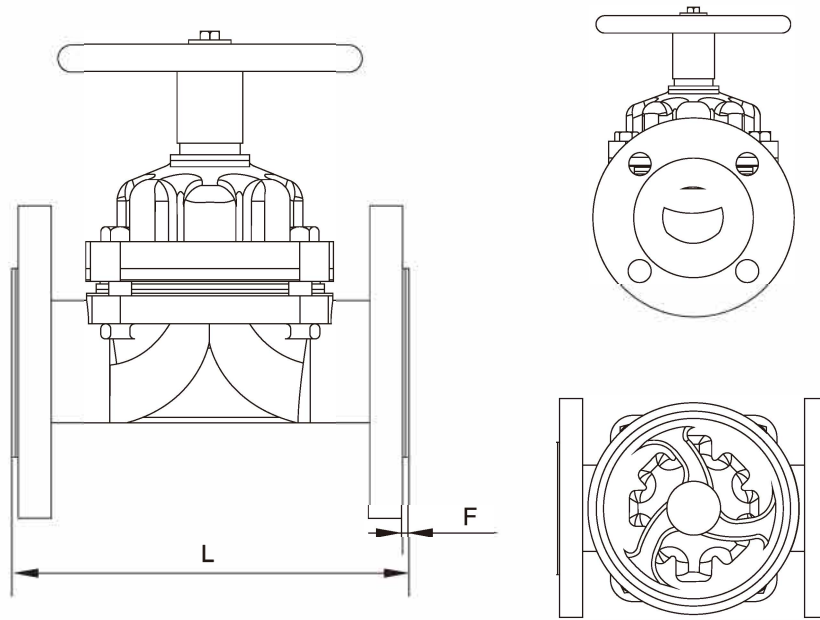

* Unit: mm **DIMENSION**

DN	NPS	ASME B16.5		JIS B2212 10K DIN2532 Pn10		BS 5156		Weight	CV
mm	in	L	f	L	f	L	f	[kg]	
15	½	108	3	130	3	108	3	3.5	10
20	¾	146	3	150	3	117	3	4	12
25	1	146	3	160	3	127	3	5.5	17
32	1¼	159	3	180	3	146	3	8	27
40	1½	175	3	200	3	159	3	11	39
50	2	200	3	230	3	190	3	14	70
65	2½	226	3	290	3	216	3	23	125
80	3	260	4	310	4	254	4	29	180
100	4	327	4	350	4	305	4	46	305
125	5	400	4	400	4	356	4	70	412
150	6	480	4	480	4	406	4	90	712
200	8	600	4	600	4	521	4	160	1011
250	10	730	4	730	4	635	4	230	1840
300	12	850	5	850	5	749	5	320	2435

www.specsvalve.com



WENZHOU SPECS VALVE CO., LTD

Tel:+86-577-67379084

Fax:+86-577-66997700

Email:info@specsvalve.com

Add:Dong'ou Industrial Zone, Oubei Town,
Wenzhou City, Zhejiang Province, China
